

LED Snaplight® & Retrofit Tray

Designed to upgrade linear fluorescent fixtures
Vibration-resistant for demanding applications
Superior corrosion resistance
LED technology increases efficiency, eliminates maintenance and supports green initiatives



Key Applications

Exterior and interior decks
Exterior wet locations
Maintenance rooms
Holding areas
Machine houses
Electrical and engine rooms
Wash down areas
Emergency lighting
Parking garages
Stairwells

Compliances

UL/cUL Listed to:

- UL 1598 Suitable for Wet Locations
- UL 1598C LED Retrofit Conversion (retrofit kits only)
- CSA C22.2 No. 250.0-08

UL Listed to:

- UL 1598A Marine Outside Type (Saltwater)
- UL 924 Emergency Lighting Equipment

ABS

IP65

CE

FCC Part 15, Subpart B, Class A standards for conducted and radiated emissions.

Buy American Act (BAA)

Specifications

Construction	Corrosion-free, high impact, glass reinforced, UV-stabilized nylon housing
Hardware	Captive and non-magnetic stainless steel external hardware
Lens	High-impact polycarbonate, matte finish Tethered to housing
Light source	2 foot fixture - up to 3700 lumens (29W) 4 foot fixture - up to 6400 lumens (49W) CRI > 80 Cool white 5000K (50K) or neutral white 4000K (40K) LED options Field adjustable light output (see dimming level chart) Switchable red (RED) and blue (BLU) LED options 50,000 hour rated life
Power source	120-277V, 50/60Hz 0-10V dimming capable (standard)
Wiring	¾ inch NPT threaded conduit openings on both ends Threaded plug and cable gland provided
EMB	Input power 120-277, 50/60Hz Minimum 120 minute run time (EMB2) Approximately 1600 lumens
Ambient operating temperature	-18°C to +55°C (2ft standard) -18°C to +40°C (4ft standard) 0°C to +40°C (EMB)
Retrofit kit	Internal driver tray complete with LED and driver Retrofits into Phoenix LFSB and LFW fixtures
Warranty	3 years

For IES files, see website or contact factory



This product complies with domestic preference requirements such as BAA or TAA.
For additional information, visit phoenixlighting.com or consult your representative.

ReadiLED™ Series

LED Snaplight® & Retrofit Tray

PHOENIX®
DURABILITY X DESIGN™

Dimming Levels (RLED-2)

RLED-2	Watts	Estimated Lumens
Position 1	29	3700
Position 2	23	3000
Position 3	13	1600
Position 4	7	700

Dimming Levels (RLED-4)

RLED-4	Watts	Estimated Lumens
Position 1	49	6400
Position 2	39	5000
Position 3	19	2500
Position 4	8	900

Dimensions

2 Foot

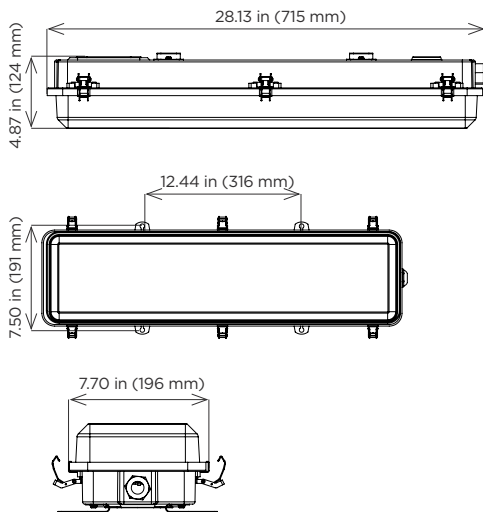

4 Foot

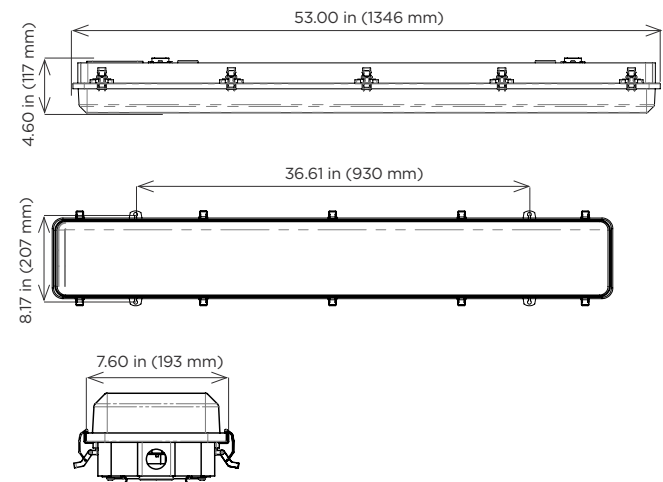

Ordering Information

Example: RLED-4-DF-50K

Fixture	Size	Lens ⁵	Color Temperature	Switchable Color	Options
RLED	2	DF	40K	RED ^{1,3}	EMB2 ²
RLED-RFK ^{1,4}	4		50K	BLU ^{1,3}	

Fixture	Size	Lens ⁵
RLED ReadiLED fixture	2 2 foot	DF diffused lens
RLED-RFK ^{1,4} ReadiLED retrofit kit	4 4 foot	

Color Temperature	Switchable Color	Options
40K 4000K LEDs	RED ^{1,3} Ability to switch from white (4000K) to red light	EMB2 ² Emergency battery backup (120 minutes)
50K 5000K LEDs	BLU ^{1,3} Ability to switch from white (4000K) to blue light	

Notes

- 1 Not CE certified
- 2 Minimum 120 minute run time. Meets Coast Guard Subchapter M requirements 140.410 for Emergency Shipboard Lighting.
- 3 Only available with 4000K (40K) color temperature.
- 4 Retrofit kit provided with internal LED/ driver tray only (no housing or lens).
- 5 Leave blank for retrofit kit models as no lens is supplied.

Special Projects: We may be able to accommodate your special projects, so please don't hesitate to ask about additional options. Minimum order quantities and/or extended lead times will apply. Contact your Phoenix representative with specific inquiries.