



Compact fixture design delivers up to 1000 lumens

Competitive pricing with short lead times

Ideal replacement for jelly jars and all wall mount vaporproof fixtures

LED technology increases efficiency, eliminates maintenance and supports green initiatives

### Dimensions

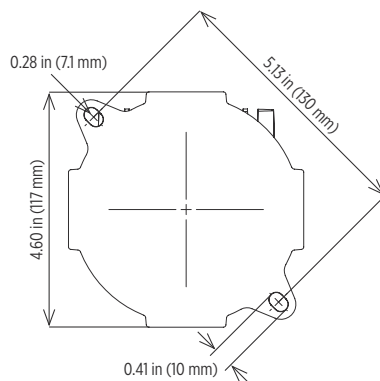
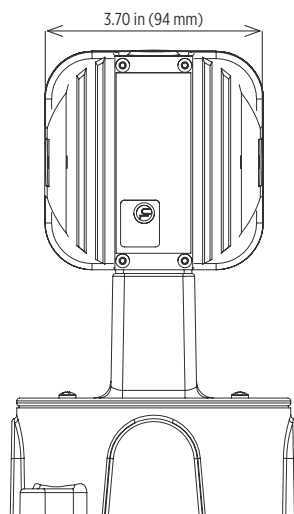
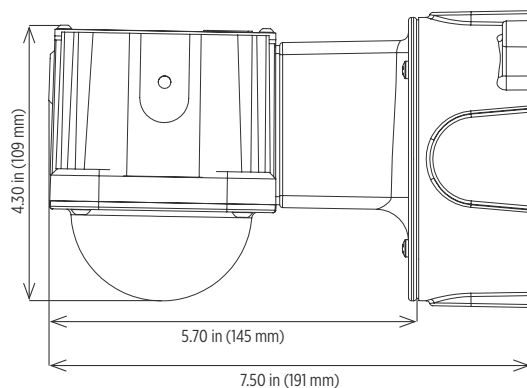

### Specifications

<b>Construction</b>	Cast aluminum housing Marine grade cast aluminum wall mount bracket Marine grade cast aluminum junction box (optional)
<b>Finish</b>	White thermoset powder coat (fixture)
<b>Hardware</b>	Marine grade (316) stainless steel
<b>Lens</b>	Impact-resistant, diffuse polycarbonate Color lens kit accessories are available (AMB-CL, BLU-CL, GRN-CL, RED-CL)
<b>Light source</b>	13W, up to 1000 lumens Conformal coating CRI ≥ 80 CCT 5000K 50,000 hour rated life
<b>Power source</b>	120-240V, 50/60Hz 240V, 50/60Hz 13-27V DC
<b>Wiring</b>	Stranded wires
<b>Outlets</b>	One ½ inch NPT outlet for power connection
<b>Ambient operating temperature</b>	-30°C to +50°C
<b>Weight</b>	4.0 lb (1.8 kg)
<b>Warranty</b>	3 years

For IES files, see website or contact factory

### Compliances

ETL/cETL Certified to:

- UL 1598 Suitable for Wet Locations
- UL 1598A Marine Outside Type (Saltwater)
- CSA C22.2 No. 250.0

CE

IP66

LM79 and LM80 reports available



# Cube-Light Wall Mount

Compact LED Area Light

**PHOENIX**<sup>®</sup>  
DURABILITY X DESIGN™

## Ordering Information

Example: CLW-13LED-120-240

Fixture	Watt/Type	Voltage	Option
CLW	13LED	120-240 <sup>1,2</sup> 240 <sup>2</sup> DC <sup>1</sup>	NB <sup>2</sup>

Watt/Type	Voltage	Option
13LED 13W, up to 1000 lumens	120-240 <sup>1,2</sup> 120-240V, 50/60Hz 240 <sup>2</sup> 240V, 50/60Hz DC <sup>3</sup> 13-27V DC	NB <sup>2</sup> No junction box

### Notes

- 1 ETL/cETL listed
- 2 CE
- 3 No certifications

**Special Projects:** We may be able to accommodate your special projects, so please don't hesitate to ask about additional options. Minimum order quantities and/or extended lead times will apply. Contact your Phoenix representative with specific inquiries.

## Accessories (order separately)

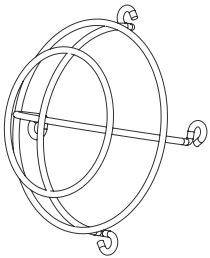

### Wire Guard Kit

WG-CL

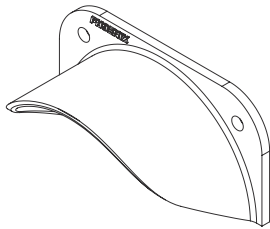

### Visor Kit

VSR-CL

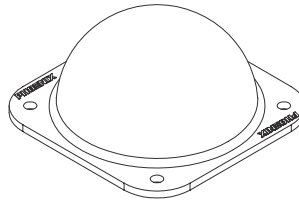

### Color Lens Kits

AMB-CL amber lens kit  
BLU-CL blue lens kit  
GRN-CL green lens kit  
RED-CL red lens kit

Product design and specifications are subject to change without notice. The most current version of this specification sheet can be found on our website: [www.phoenixlighting.com](http://www.phoenixlighting.com).