



18W LED floodlight designed to replace 250W quartz halogen fixtures

Durable, compact design with various accessories available

Ideal for maintenance lighting, task lighting, tracking lighting and other demanding applications

LED technology increases efficiency, eliminates maintenance and supports green initiatives

### Key Applications

Dragline track lighting  
Utility Vehicle Lighting  
Emergency Vehicle Lighting  
Shakeout Equipment Lighting  
Inspection Station Lighting  
Marine Vessel Deck Lighting  
Outdoor Spot Lighting  
Port Equipment Gantry Lighting  
Straddle Carriers  
Logo Lighting

Task Lighting  
Maintenance Lighting  
Machine Stations  
Security Lighting  
Crane Lighting  
Embarkation Lighting  
Davit Lighting  
Maintenance Platform  
Truck Lane Lighting

### Compliances

ETL/cETL Certified to:

- UL 1598 Suitable for Wet Locations
- UL 1598A Marine Outside Type (Saltwater)
- CSA C22.2 No. 250.0-08

ABS

IP69K

IK10

LM79 and LM80 reports available

### Dimensions

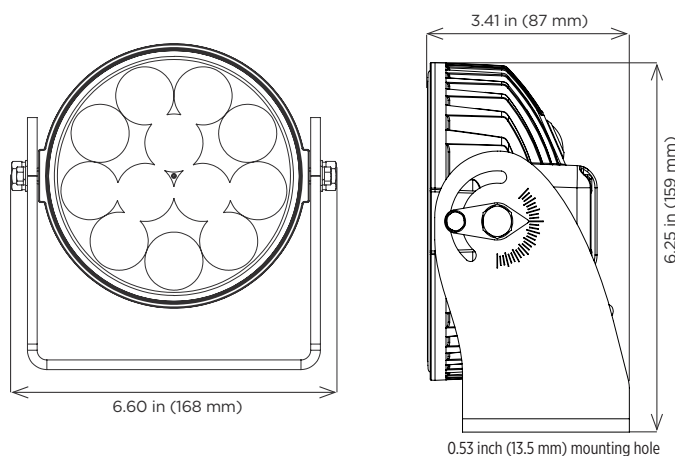

### Specifications

<b>Construction</b>	Marine grade cast aluminum housing
<b>Finish</b>	Black textured polyester powder coat
<b>Hardware</b>	Marine grade (316) stainless steel
<b>Lens</b>	Impact resistant, clear polycarbonate
<b>Light source</b>	Osram LEDs 18W Up to 2500 lumens CRI ≥ 70 CCT 5000K Spot (25°) and flood (42°) optics 50,000 hour rated life
<b>Power source</b>	100-277V, 50/60Hz 72.00 inch (1829 mm) cord with pigtail NEMA 5-15 plug accessory available (120V only)
<b>Wiring</b>	Stranded wires
<b>Ambient operating temperature</b>	-40°C to +50°C
<b>Mounting</b>	Marine grade (316) stainless steel mounting harp 0.53 inch (13.5 mm) mounting hole clearance Magnet base accessory (MBA)
<b>Shock</b>	65G along 3 axes
<b>Vibration</b>	15 Grms, 100-2200Hz along 3 axes
<b>Estimated weight</b>	Fixture: 3.75 lb (1.7 kg) Packaged: 5.0 lb (2.3 kg)
<b>Carton size</b>	8.39 in x 8.23 in x 5.67 in (213 mm x 209 mm x 140 mm)
<b>Warranty</b>	5 years

For IES files, see website or contact factory

### Ordering Information

Example: GND-12LED-SP

Fixture	LED Count	Optics
GND	12LED	FL
		SP

#### LED Count

12LED 12 LEDs, 18W,  
up to 2500 lumens

#### Optic

FL flood (42°)  
SP spot (25°)

**Special Projects:** We may be able to accommodate your special projects, so please don't hesitate to ask about additional options. Minimum order quantities and/or extended lead times will apply. Contact your Phoenix representative with specific inquiries.

### Ordering Information

#### Magnet Base Assembly

MBA

#### NEMA 5-15 Plug Kit (120V only)

PLG-515

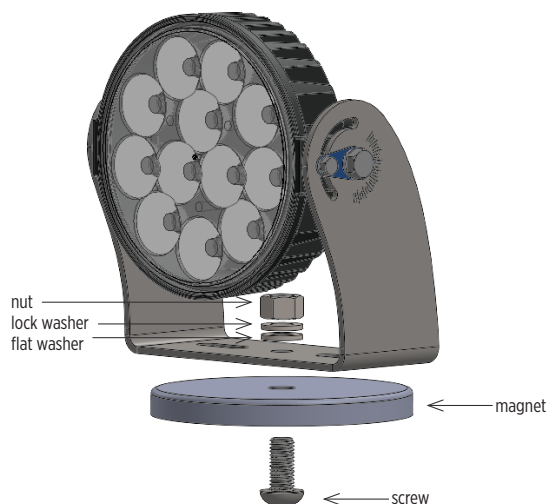

#### MBA notes:

- Includes magnet, screw, nut, lock washer and flat washer
- Not a suitable replacement for permanent installation
- Do not use MBA in hazardous environments
- Holding strength will vary based on application
- Holding strength for fixture and magnetic base must be deemed suitable by user