

## ! CAUTION

- All wiring should be done by a licensed electrician in accordance with state codes, local codes and National Electric Code (NEC) standards.
- Improper installation may result in serious injury and void warranty.
- Contains parts and assemblies susceptible to damage by electrostatic discharge (ESD).
- These instructions include information for installations in both hazardous locations and marine locations. Many sections apply to both applications. The appropriate warning and special instructions should be followed, depending on the application. Only fixtures marked “electric fixtures for hazardous locations” are suitable for installation in hazardous locations.

## General Information

Phoenix’s explosion-proof fixtures meet the requirements of UL Standard 1598, 1598A, 844 and CSA Standard C22.2, No.250, 94.0, 213.0, 137.0, 30.0 regarding electric luminaires for use in Class I, Div. 1, Groups C&D; Class I, Div. 2, Groups A, B, C, D; Class II, Div. 1, Groups F & G; Class II, Div. 2, Groups F & G; and Class III, Div. 1 & 2. For marine applications, installation must be in accordance with USCG 46 CFR parts 110 through 113.

## Mounting and Wiring

This fixture is designed for wall or ceiling mounting. It mounts to a flat surface with a single 0.50 inch (1.3 cm) bolt (not supplied). The fixture has 72 inches (183.0 cm) of #16 gauge wire for connecting at the wall mounted switch or junction box through ½” size flexible coupling or threaded, rigid conduit. The wire entrance to the light head is factory sealed and threaded to accept a 0.50 inch threaded conduit or union. Wiring must comply with Class I Division 1 and Class II Division 1 wiring methods defined in National Electric Code (NEC). Figure 1 shows suggested mounting configurations and wiring methods. Table 1 identifies the Class I and Class II components used in these suggested installations. Flexible coupling, junction box and any other part required to complete wiring are not furnished with the fixture. These items must be ordered separately through a local distributor.

## Fixture Installation

1. Mount fixture assembly to wall (or ceiling). One 0.50 inch (1.3 cm) bolt is required for mounting (not supplied).
2. Locate power supply junction box or switch close enough to fixture so that wire splices between the junction box and fixture are not required (see Figure 1).
3. If flexible coupling is being used to connect to the fixture, make certain that all bends in the coupling have a radius of at least 10 inches (25.4 cm).

**Note:** All threaded connections must engage five (5) full threads.

## Aiming

The fixture should be aimed prior to wiring to the source of power. After the fixture is connected, positioning freedom will be limited by any rigid conduit used in the electrical hookup. Fixture elevation angle may be adjusted 61°. It is limited by the position to the pin and the ears on the sealed elbow assembly (Item 6 on page 3). The elevation angle may be further adjusted if necessary by changing the position of the pin in the following manner:

Refer to Figures 2A and 2B:

1. Remove pin from hole “A” in boss of the shell (Figure 2A).
2. Rotate shell 90° with respect to sealed elbow assembly as shown on Figure 2B.
3. Drive pin in hole “B” in the boss of the shell (Figure 2B).

**Table 1**

Item in Figure 1	Acceptable Components - UL Listed for Wiring Fixtures in Class I, Division 1, Groups C and D and Class II, Division 1, Groups F and G Installations
A	0.50 inch size male union
B	0.50 inch size rigid conduit
C	0.50 inch size 90° female elbow
D	0.50 inch size diameter flexible coupling, 36.0 inch (91.4 cm) long with two (2) removable close nipples

**Figure 1**

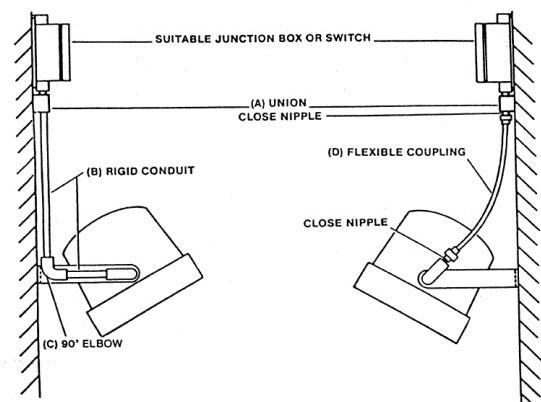

### Cover Glass Replacement

If the Lens Assembly (Item 3 on page 3) is to be replaced, first loosen the Retaining Ring (see below) by turning it counterclockwise with a hammer and drift punch applied to the lugs on the ring. Once loose, it may be rotated by hand. Remove the Cover Glass and Cover O-Ring, which should also be replaced.

The threads in the Cover, Retaining Ring, and Shell should be thoroughly cleaned and lubricated liberally with a non-drying grease or petrolatum to facilitate assembly and disassembly and to inhibit corrosion. After replacement of the Cover O-Ring and the Cover Glass, the Retaining Ring must be tightened against the glass with the hammer and the drift punch until the clearance between the Cover Glass and the Cover is such that a 0.0015" (0.004 cm) feeler will not enter the joint more than 0.125 inch (0.30 cm) at any point, as shown in below.

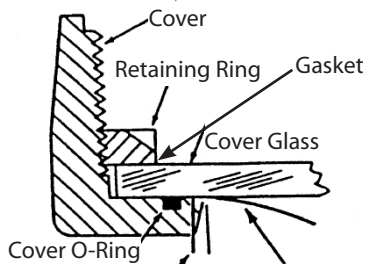

0.125 inch (0.30 cm) Penetration (MAX) 0.0015" (0.004 cm) Feeler

Figure 2A

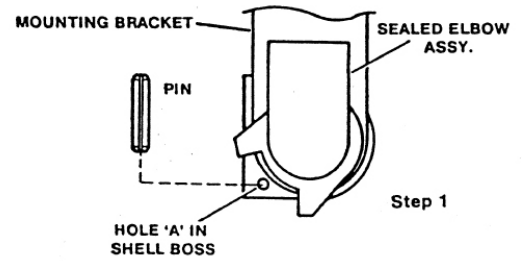
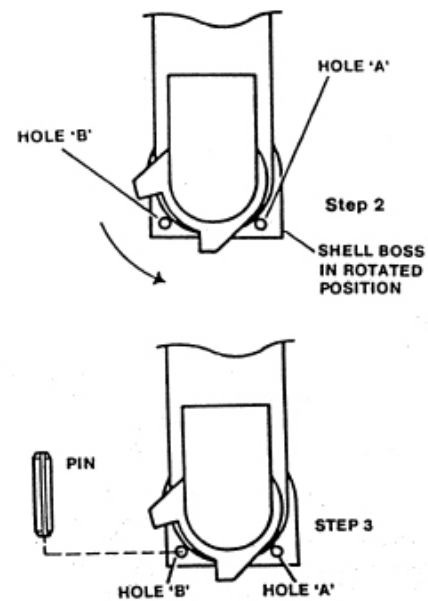

Figure 2B



### Removal and Replacement of Cover

In most cases, a rectangular steel bar about 0.75 inch (1.9 cm) × 0.50 inch (1.3 cm) × approximately 30 inches (76.0 cm) can be placed between the lugs provided on the face of the cover and rotated counterclockwise to accomplish the removal. See figure below. Excessive force must not be used as bar may slip and cause injury.

Before replacing the cover, thoroughly clean the threads in both the cover and shell, then lubricate threads with thin film of a non-drying grease or petrolatum. This will enable the cover to be turned more easily and will facilitate its removal later.

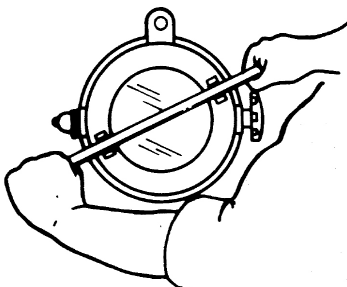

Product design and specifications are subject to change without notice.

### Repair Parts

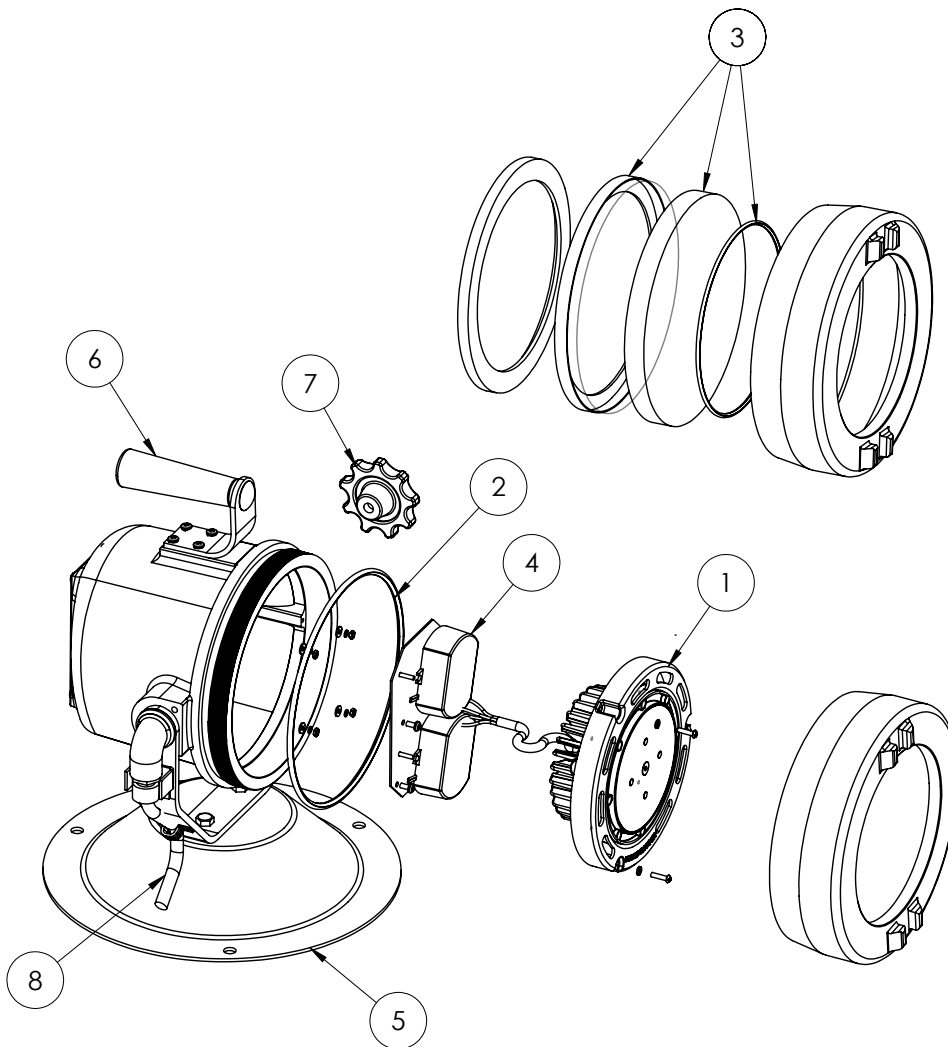

### Repair Parts List

Item No.	Repair Part	Part Number
1	LED module - flood optic (V1)	Obsolete
	LED module - flood optic (V2)	1804102
	LED module - spot optic (V1)	1804101
	LED module - spot optic (V2)	1804103
2	gasket	5002203
3	lens assembly	1863206
4	driver (2 required per fixture)	4380002
5	harp	2410003
6	elbow assembly	1860011

Product design and specifications are subject to change without notice.