



Built for stability and smooth operation  
Durable design in safety yellow for maximum visibility  
Available in 40 and 60 inch lengths

### Compliances

ETL/cETL Certified to:

- UL 1598 Suitable for damp locations
- CSA C22.2 No. 250.0 equivalent

### Specifications

|                     |   |
|---------------------|---|
| <b>Construction</b> | 1.60 inch square steel tube arms with lateral mobility joint<br>Washers at all joints and bushings at bracket joints<br>40 and 60 inch double strut arms – standard |
| <b>Finish</b>       | Safety yellow powder coat   |
| <b>Hardware</b>     | Zinc plated   |
| <b>Wiring</b>       | 120V<br>On-off switch and two (2) IEC type receptacles<br>Ability to plug in and carry weight of dock light head and fan  |
| <b>Mounting</b>     | Powder coated steel mounting bracket  |
| <b>Warranty</b>     | 1 year  |

Contact factory for IES files

### Dimensions

#### 40 Inch Arm

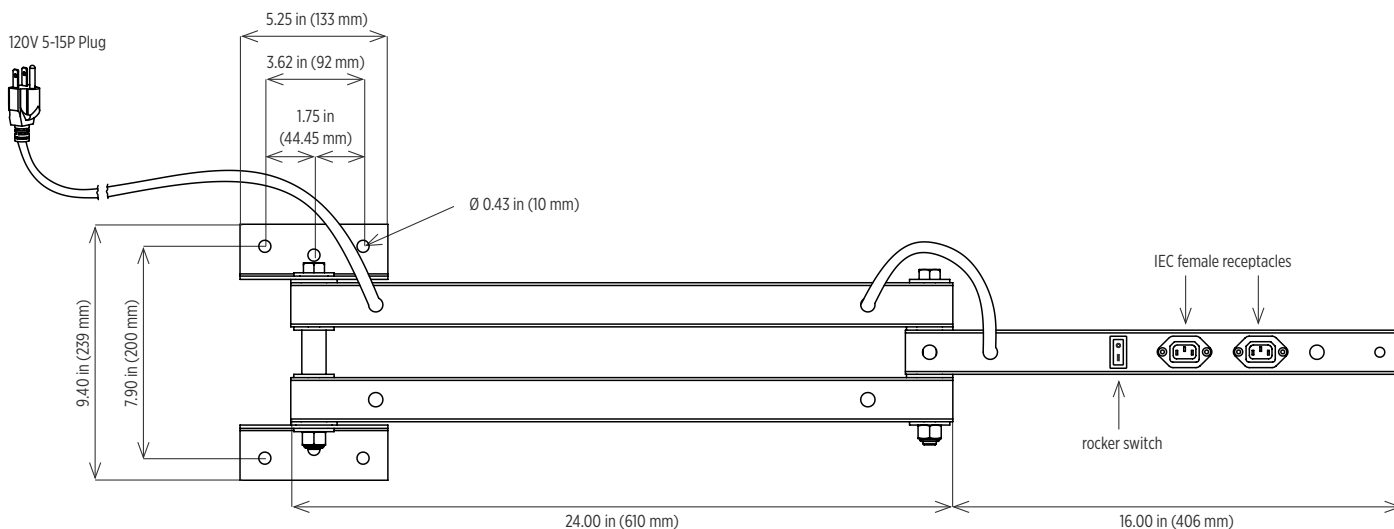

# Modular *docklite*® Arm

Arms for Loading Dock Lighting

## Dimensions

### 60 Inch Arm

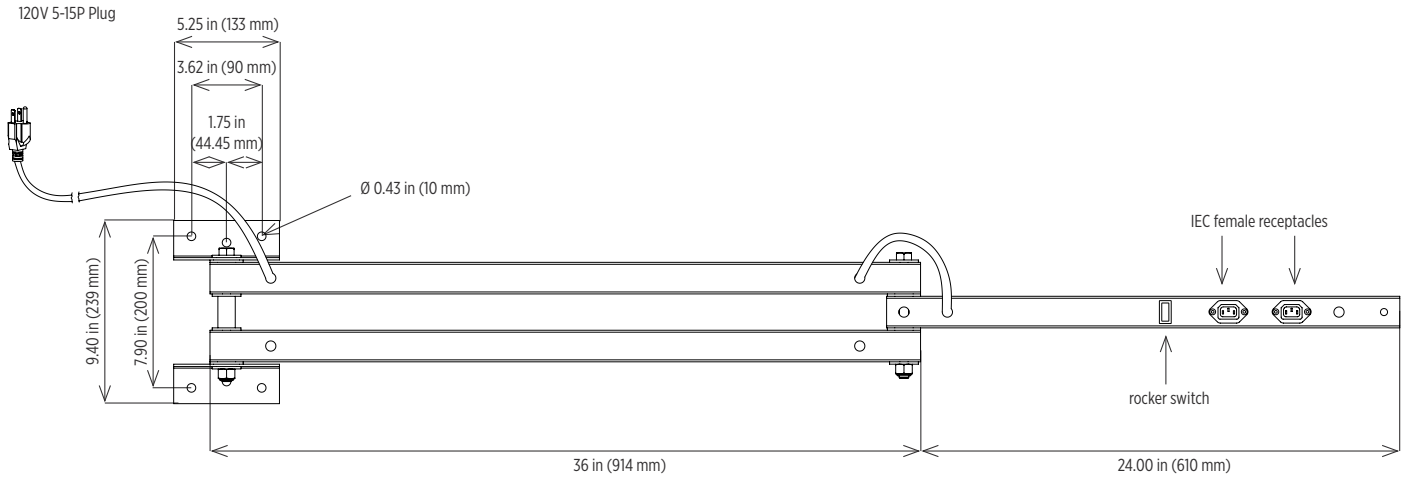

## Ordering Information

Example: DLSD-40-ARM-DS

| Series | Length | Part | Construction |
|--------|--------|------|--------------|
| DLSD   | 40     | ARM  | DS           |
|        | 60     |      |              |

**Special Projects:** We may be able to accommodate your special projects, so please don't hesitate to ask about additional options. Minimum order quantities and/or extended lead times will apply. Contact your Phoenix representative with specific inquiries.

## Accessories (order separately)



**Modular Light Head**  
DL-INC-LH-LMP



**LED Light Head**  
DLA2-12LED

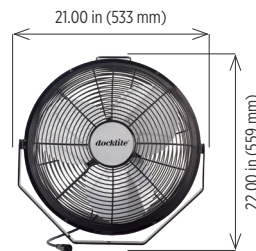

**Fan**  
DL-FAN-18

Product design and specifications are subject to change without notice. The most current version of this specification sheet can be found on our website: [www.phoenixlighting.com](http://www.phoenixlighting.com).