

! CAUTION

- All wiring should be done by a licensed electrician in accordance with state codes, local codes, National Electric Code (NEC) standards and International Electrotechnical Commission (IEC) standards.
- Improper installation may result in serious injury and void warranty.
- Keep plugs and receptacles dry. This fixture should only be used on Ground Fault Circuit Interrupter (GFCI) protected circuits.
- Contains parts and assemblies susceptible to damage by electrostatic discharge (ESD).
- When using luminaires, basic safety precautions should always be followed to reduce the risk of fire, electric shock and personal injury.
- Maximum distance to the receptacle is determined by the length of the cord provided.

Installation

Identify the desired mounting location for the fixture, keeping in mind that the SturdiLED[®] can be surface or tenon mounted.

Surface Mount

Figure 1

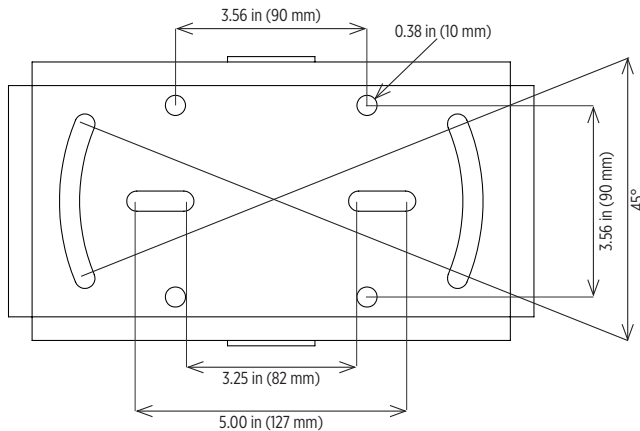

Tenon Mount

When tenon mounting, the fixture should be mounted using the mounting bolts provided. Note: fixture is designed to accommodate two different pipe sizes. Refer to Figure 4 below.

Figure 4

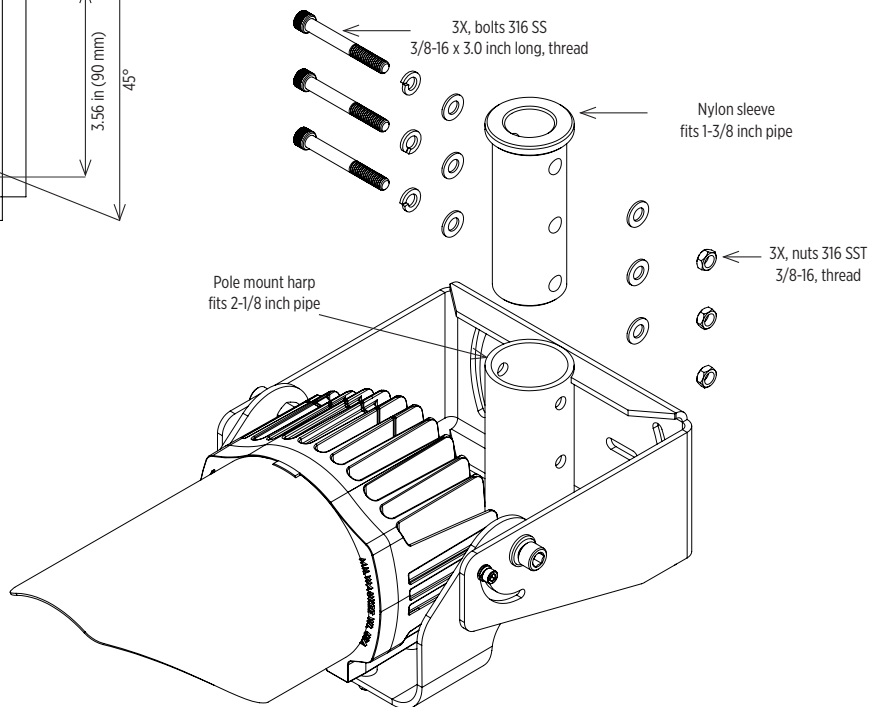

Wiring

Standard fixture is supplied with 72.00 in (1829 mm) cable and SYM 1218.3 plug.

Product design and specifications are subject to change without notice.



Aiming

Figure 2

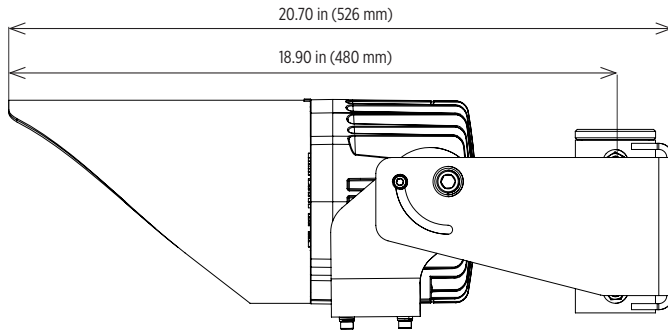
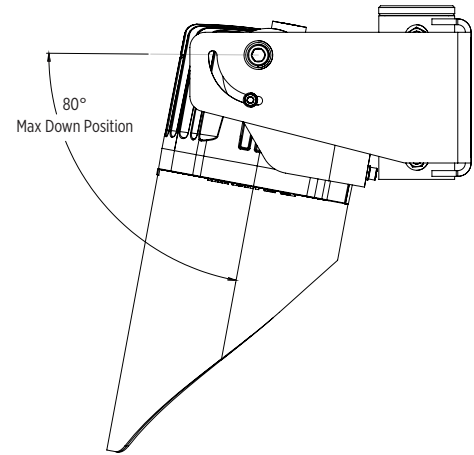

Figure 3



Repair Parts List

Repair Part	Part Number
28° optic lens assembly	010184.900
45° optic lens assembly	010184.901
4000K LED board assembly	010184.915
red LED board assembly	010184.916
amber LED board assembly	010184.917
NVIS cyan LED board assembly	010184.918
blue LED board assembly	010184.919
120V triac driver kit	010184.920
back cover assembly (gray)	010184.921
NPL mounting bracket assembly (gray)	010184.922
extended visor kit (gray)	010184.923

Maintenance

Periodic maintenance and cleaning is required to keep light fixture in peak operating condition. Buildup of dirt and/or debris will diminish performance, lead to premature failure and void the fixture's warranty.

1. Inspect fixture monthly or (more frequently if conditions require) for dirt and debris buildup on lenses and between fins of heatsink. Wash down with water as needed.
2. Inspect fasteners and verify cord grips are tight. Retighten as needed.
Note: Cord grips should be hand tight plus ¼ turn.

Product design and specifications are subject to change without notice. The most current version of this document can be found on our website, www.phoenixlighting.com.