

! CAUTION

- All wiring should be done by a licensed electrician in accordance with state codes, local codes, and National Electric Code (NEC) standards or International Electric Commission (IEC) standards.
- Improper installation may result in serious injury and void warranty.
- Contains parts and assemblies susceptible to damage by electrostatic discharge (ESD).
- When using luminaires, basic safety precautions should always be followed to reduce the risk of fire, electric shock and personal injury.

Wiring

The standard fixture is supplied with wire leads.

Green/yellow is ground (PE), brown is line and blue is neutral.

Pole Mount Installation

The CVO Series fixture fits on a 1.25 inch (32 mm) trade size pipe.

1. Identify the desired mounting location for the fixture. To prevent water intrusion, the CVO Series must be mounted in a horizontal, downward-facing position (maximum of 25° from horizontal). If Dark Sky approval is required, fixture must be horizontal.
2. Make wire connections (refer to 'Wiring' section above).
3. Insert wire connections into pipe.
4. Secure fixture to pipe using pipe mount bracket and two (2) M8 bolts (supplied). Refer to Figure 1.

Wall Mount Installation

For stationary applications only. For high vibration applications, use Pole Mount installation.

1. Identify the desired mounting location for the fixture. To prevent water intrusion, the CVO Series must be mounted in a horizontal, downward-facing position (maximum of 25° from horizontal). If Dark Sky approval is required, fixture must be horizontal.
2. Mount fixture to desired surface using three (3) ¼-20 or M6 hardware (not supplied).
3. Using wall mount wire cover (shown in Figure 2), select which entry point (side or bottom) is appropriate for your application. Either conduit or flexible cable can be used for power supply.
4. Make wire connections (refer to 'Wiring' section above).
5. Using two (2) M8 bolts (supplied), secure wall mount wire cover to fixture.

Figure 1

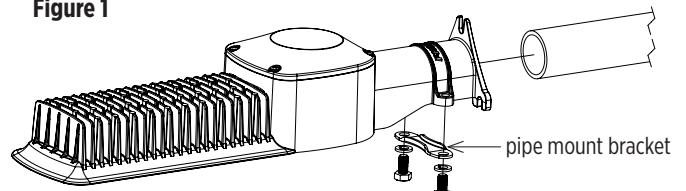

Figure 2

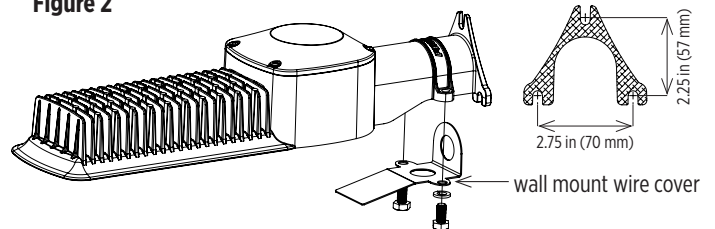
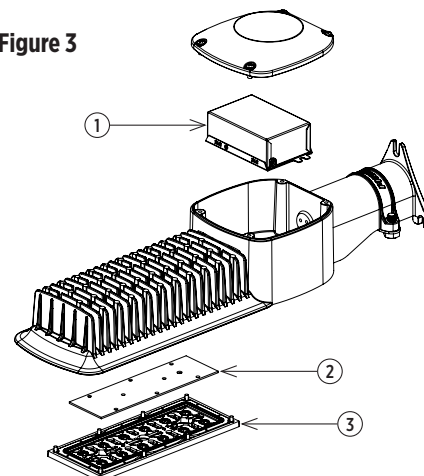

Figure 3



Maintenance

Periodic maintenance and cleaning is recommended to keep light fixture in peak operating condition. Buildup of dirt and/or debris will diminish performance, lead to premature failure and void the fixture's warranty.

Inspect fixture monthly (or more frequently if conditions require) for dirt and debris buildup on lenses and between fins of heatsink. Wash down with water as needed.

Repair Parts List

Item	Part Number	Description
1	4380054	120-277V driver
2	4390010	cool white (5000K) circuit board
3	1090760	lens kit