



Heavy duty searchlight rated for wet locations

Designed for easy aiming

Simple, no-tool relamping and maintenance

For use in heavy duty marine environments

Dimensions

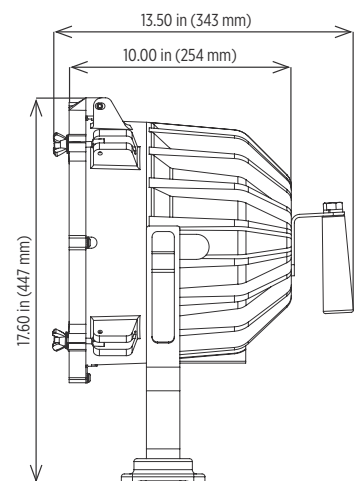
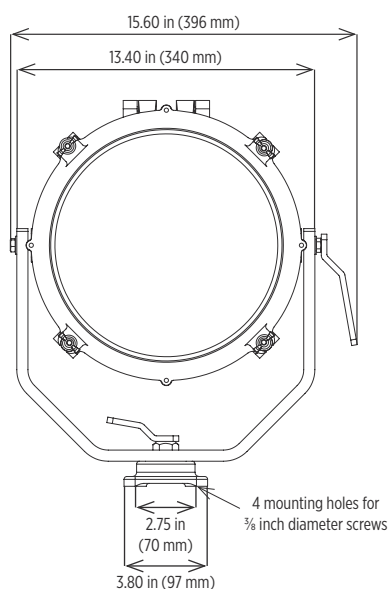

Specifications

Construction	Copper-free cast aluminum housing
Finish	Phoenix green thermoset powder coat
Hardware	Stainless steel external hardware
Lens	Clear heat-resistant tempered cover lens
Aiming	Dual axis with full grip locking levers Vertical - 55° up and 30° down Horizontal - 360°
Light source	Halogen - PAR64, 1000W Extended mogul end prong lamps Lamp not included
Power source	120V, 60Hz
Wiring	4 foot (1.2 m), 3-conductor 16/3 SEO cord
Mounting	Copper-free aluminum mounting bracket
Weight	30.0 lb (13.6 kg)
Warranty	1 year

Contact factory for IES files

Compliances

UL/cUL Listed to:

- UL 1598A Marine Outside Type (Saltwater)
- UL 1598 Suitable for Wet Locations

CSA Certified Indoor/Outdoor Type 4X

ABS



MRS 64/1000S

Heavy Duty Searchlight



Ordering Information

Example: MRS64/1000S

Fixture

MRS64/1000S

Special Projects: We may be able to accommodate your special projects, so please don't hesitate to ask about additional options. Minimum order quantities and/or extended lead times will apply. Contact your Phoenix representative with specific inquiries.

Accessories (order separately)

Wire Lens Guard

WG-4

Red Glass Cover Lens

GL-R

Yellow Glass Cover Lens

GL-Y

Shock Mount Base

SMB



Meets the requirements of the
Buy American Act (BAA) and/or the
American Recovery and Reinvestment Act (ARRA)

Product design and specifications are subject to change without notice. The most current version of this specification sheet can be found on our website: www.phoenixlighting.com.



Phoenix Products Company Inc. 8711 West Port Avenue Milwaukee, WI 53224 USA
Phone: +1 414.973.3300 Toll Free: 800.438.1214 Fax: +1 414.973.3210 www.phoenixlighting.com

N5440400H
11.09.15