

Explosion-proof LED Floodlight & High Bay



Second generation HazLoc flood & high bay designed to withstand the world's harshest environments

Ideal for use in all UL1598A marine and UL844 hazardous locations

Consists of marine-grade components for superior corrosion resistance

Versatile fixture with various color temperature, optic, voltage & mounting options

Key Applications

Mining and coal production & processing
Gasoline dispensing and service stations
Petroleum and chemical refineries
Land drilling rigs
Fuel depots
Wastewater treatment plants
Paint facilities
Power plants
Grain processing and storage
Food and beverage processing facilities
Spirit distilleries
Paper and pulp mills
Aircraft hangars
Chemical and petrochemical processing facilities
Health care facilities
LNG Carriers
Petroleum & chemical tankers

Compliances

UL/cUL Certified to:

- UL 1598 Suitable for Wet Locations
- UL 1598A Marine Outside Type (Saltwater)
- UL 844 Hazardous Locations
 - Class I, Division 1 Groups B, C, D
 - Class I, Division 2 Groups A, B, C, D
 - Class II, Division 1 Groups E, F, G
 - Class II, Division 2 Groups F, G
 - Class III

IP66

IK10

ABS

Specifications

Construction	Die cast aluminum housing
Finish	Gray thermoset powder coat
Hardware	316 stainless steel external hardware
Lens	Clear, tempered glass
Light source	14,000 lumens - 100W 28,000 lumens - 200W CRI ≥ 70 CCT 5000K (50K), 4000K (40K) and 3000K (30K) 100,000 hour rated life
Power source	120-277V, 50/60Hz or 277-480V, 50/60Hz 1-10V dimming capability 6kV surge protection
Wiring	3 x ¾ inch NPT openings
Ambient operating temperature	DFN2-HI-100: -40°C to +65°C (T4A) DFN2-HI-200: -40°C to +45°C (T4)
Salt spray	Tested to ASTM B117 for 1000 hours
Mounting	316 stainless steel mounting bracket - standard Ceiling, wall or pendant mount
Aiming	Capable of 135° rotation Refer to 'Aiming Capability' section
Weight	39.5 lb (17.9 kg)
Warranty	5 years

For IES files, see website or contact factory

Defend Flood™ 2 HI - HAZ

Explosion-proof LED Floodlight & High Bay

PHOENIX[®]
DURABILITY X DESIGN™

Dimensions

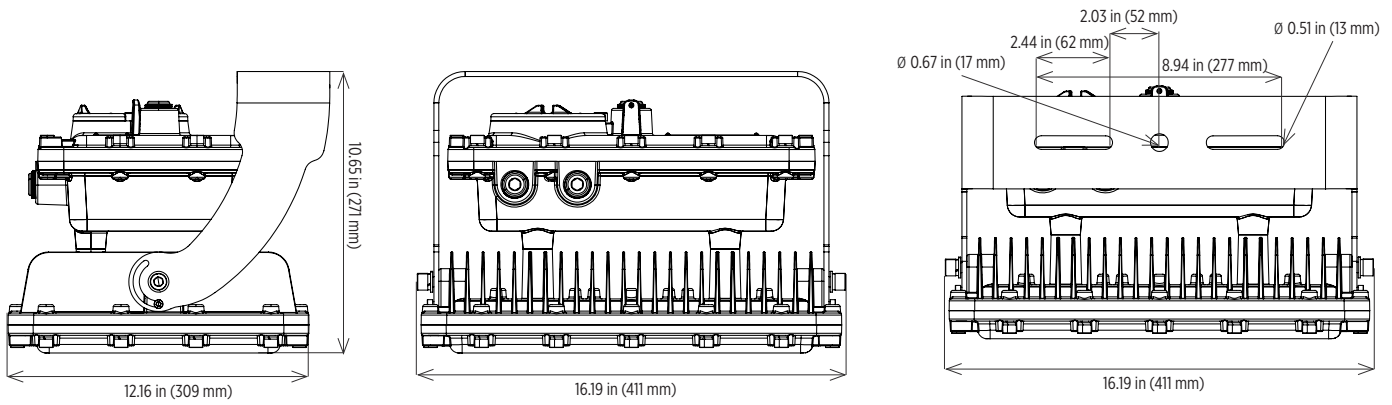

Aiming Capability

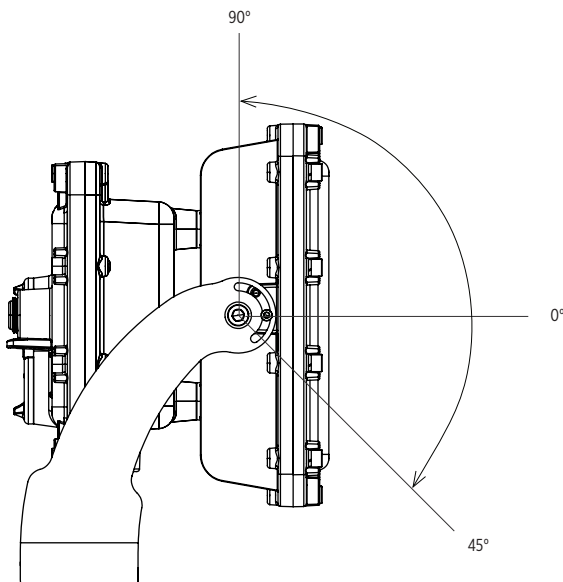

Ordering Information

Example: DFN2-HI-100-WF-120-277-50K

Fixture	Wattage	Optic	Voltage	CCT	HAZ
DFN2-HI	100	FL	120-277	50K	HAZ
	200	WF	277-480 ¹	40K ¹	
				30K ¹	

Wattage	Optic	Voltage	CCT	HAZ
100 up to 14,000 lumens - 100W	FL Flood optic (60°)	120-277 120-277V, 50/60Hz	50K 5000K	HAZ UL844
200 up to 28,000 lumens - 200W	WF Wide flood optic (120°)	277-480 ¹ 277-480V, 50/60Hz	40K ¹ 4000K 30K ¹ 3000K	Hazardous Location certified

Notes:

1 Contact factory for availability

Special Projects: We may be able to accommodate your special projects, so please don't hesitate to ask about additional options. Minimum order quantities and/or extended lead times will apply. Contact your Phoenix representative with specific inquiries.

Accessories

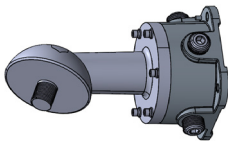

25° Stanchion Mount¹
SM25

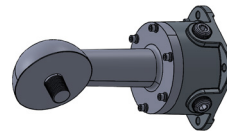

90° Stanchion Mount¹
SM90

Notes:

1 Stanchion Mounts are CSA certified to Class I, Division 1, Groups A, B, C and D; Class I, Division 2, Groups A, B, C and D; Class II, Division 1, Groups E, F and G; Class II, Division 2, Groups F & G, Class III.