

Designed to illuminate the “danger zone” surrounding large mobile equipment

Provides a distinct, narrow, red beam to promote safety

Compact, low profile design with adjustable mounting harp
LED technology increases efficiency, eliminates maintenance and supports green initiatives

Key Applications

Danger zone illumination for large AC & DC mobile equipment
Safety lighting
Perimeter lighting
Indicator lighting
Overhead crane indication lighting

Compliances

ETL/cETL Certified to:

- UL 1598 Suitable for Wet Locations
- UL 1598A Marine Outside Type (Saltwater)
- CSA C22.2 No. 250.0
- CE
- IP66

Specifications

Construction	Marine grade, extruded aluminum housing Marine grade, die cast aluminum end plates
Finish	Anodized finish on extruded parts Thermoset powder coat paint on die cast parts
Hardware	Marine grade (316) stainless steel
Lens	Impact resistant polycarbonate Customized linear optic
Light source	Red LEDs (up to 48W (UNIV) and up to 53W (DC), 3800 lumens) - standard Green LEDs option (up to 54W (UNIV), 4100 lumens) - (GRN) Conformally coated circuit boards 50,000 hour rated life
Power source	120-277V, 50-60Hz (UNIV); 12-24V (DC) Fully potted Replaceable
Power factor	> 0.9 at 120V
Surge protection	20kV/kA
Wiring	Wire leads standard (connectors accept up to 12 AWG wire)
Through wiring	Standard fixture is designed for continuous row mounting
Ambient operating temperature	-40°C to +50°C
Mounting	Harp mount
Estimated fixture weight	DNG-1 - 12.0 lb (5.4 kg) DNG-2 - 16.5 lb (7.5 kg)
Warranty	5 years

For IES files, see website or contact factory

Danger Light™

Heavy Duty LED

PHOENIX[®]
DURABILITY X DESIGN™

Dimensions

DNG-1

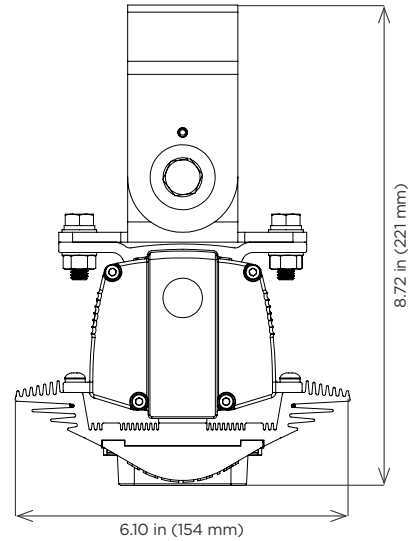
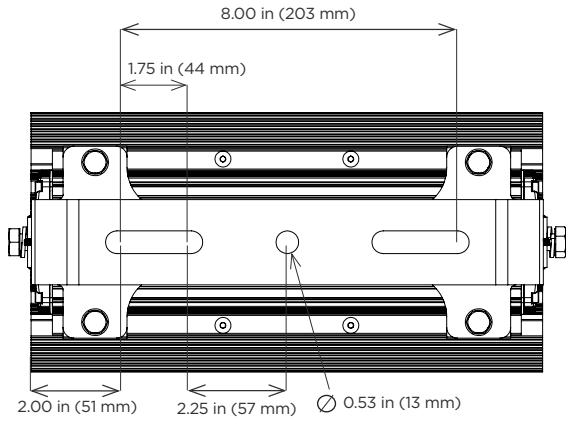

DNG-2

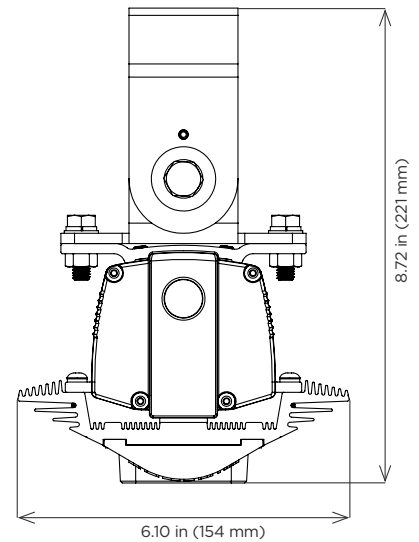
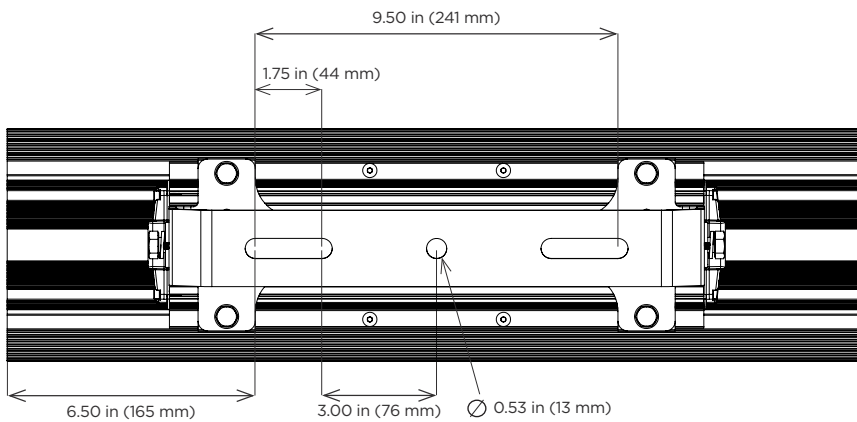

Ordering Information

Example: DNG-2-UNIV

Fixture	Circuit Boards	Voltage	Options ¹	Generation
DNG	1	UNIV	GRN ^{1,2}	V2
	2	DC		

Circuit Boards

- One circuit board (up to 1900 lumens - red, up to 2050 lumens - green)
- Two circuit boards (up to 3800 lumens - red, up to 4100 lumens - green)

Voltage

- UNIV 120-277V, 50-60Hz
DC 12-24V

Options

- GRN ^{1,2} Green LEDs

Generation

- V2 Version 2 - standard on DNG-2-UNIV models (not available on DC models)

Notes

- Standard Danger Light™ fixture comes with red LEDs. Leave blank.
- Green LED option only available on 120-277V (UNIV) models.

Special Projects: We may be able to accommodate your special projects, so please don't hesitate to ask about additional options. Minimum order quantities and/or extended lead times will apply. Contact your Phoenix representative with specific inquiries.

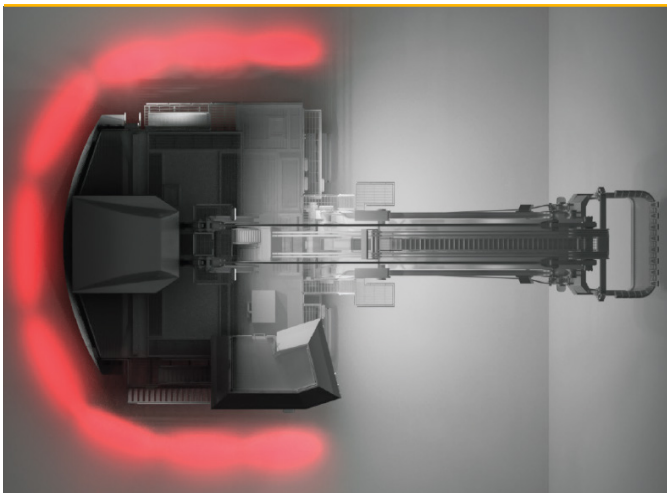

Top view rendering of an electric rope shovel outfitted with nine Danger Lights

Isolux Chart

DNG-2-UNIV and DNG-2-DC

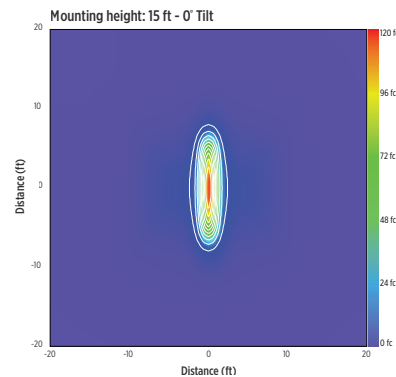

Product design and specifications are subject to change without notice. The most current version of this specification sheet can be found at www.phoenixlighting.com.