

PHOENIX®

Installation Instructions and Parts List for Light-Duty Double Strut Modular *docklite*® Arm Models: DL-42-ARM-LDDS, DL-60-ARM-LDDS

GENERAL INFORMATION

Light-Duty Double Strut Modular *docklite*® Arms can support the weight of any of our modular light heads and our modular, three-speed fan.

MOUNTING INFORMATION

This fixture should be mounted where it will not be directly exposed to the elements. It is designed for wall or post mounting and requires a flat vertical surface 4" wide by 10" high. A template, for easy anchor hole alignment (See Page 2), is provided. Four 3/8" bolts are required for mounting the 42" model (See Page 2). Six 3/8" bolts are required for mounting the 60" model (See Page 2). Slotted brackets are designed for easy placement of the final (top) two anchor holes.

For most efficient operation, we suggest mounting the fixtures so the light head, in level position, can be placed into the top corner of the lowest trailer expected to use the loading location. It should also be mounted as close to the door or opening edge as is practical. For maximum safety, mount bottom of bracket 78" from the floor (this will clear the average person). Do not mount in a manner that will allow the wall arm to be trapped under an overhead door as it is being closed. Light-Duty Double Strut Modular *docklite* Arms can support the weight of any of our modular light heads and our modular, three-speed fan. The fan and head can be mounted either above or below the arm.

Use hardware supplied with modular light head to mount it on the end of the Light Duty Double Strut arm.

WIRING AND SWITCH

Install the male plug from the modular light head into the female receptacle closest to the rocker switch. This receptacle is the one controlled by the rocker switch. The second receptacle is constantly powered as long as the arm is plugged in and is ideal for powering the three-speed fan.

Install the male plug from the arm assembly into the nearest supply outlet (120V ONLY).

Black = Line White = Common Green = Ground

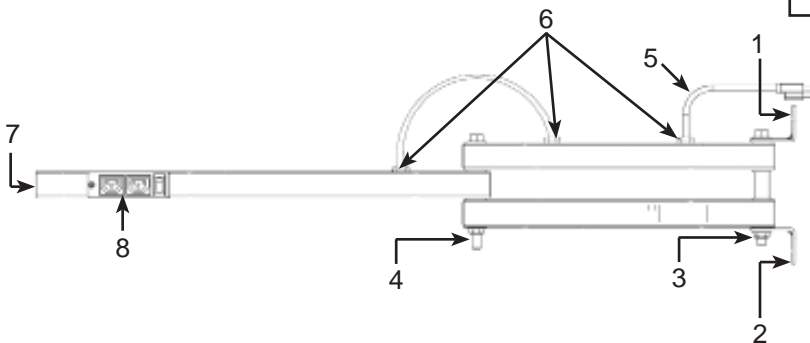
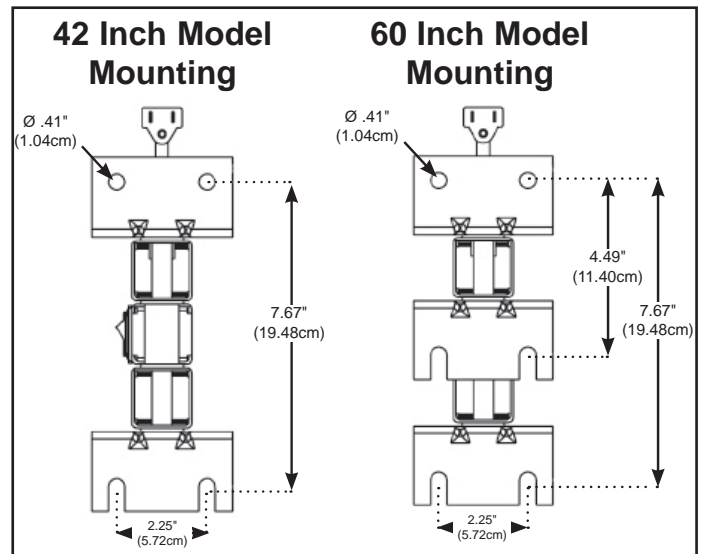

PARTS LIST

ITEM NO.	DESCRIPTION	PART NO.
1	Top mounting bracket	2323161
2	Slotted mounting bracket (2 req. for 60 inch)	2323171
3	Mounting bracket hardware kit	1865223
4	Elbow hardware kit	1865224
5	Cord assembly with plug	4130440
6	Strain relief bushing	4030200
7	End cap	5100600
8	Receptacle and switch assembly	1865225

Three Year Product Warranty -- (Limited Type)

Phoenix Products Company, Inc., warrants its products against defects in material and workmanship. Without charge, Phoenix Products Company will either repair or replace (Phoenix Products Company reserves the right to decide between repair or replacement) any properly installed Phoenix Products Company manufactured product which fails under normal operating conditions within three years from the date of invoice, provided it is returned to the factory (after authorization), transportation prepaid, and our inspection determines it to be defective under terms of this warranty.

The warranty covers only equipment manufactured by Phoenix Products Company and does not extend to transportation, installation, or replacement charges at buyer's facility; nor does it apply to any other equipment of another manufacturer used in conjunction with Phoenix Products Company equipment. No other warranty, expressed or implied, exists beyond that included in this statement.

N5499814B-1